

**University Of Technology**  
**Department Of Laser & Optoelectronics Engineering**  
**Laser And Optoelectronics Branch**

# **Lectures of AC circuits**

**Name of the lecturer: Assist. Prof. Dr. Salah  
A. Adnan**

**Branch: Laser & Optoelectronic Eng.**

**Class: 2<sup>nd</sup> year**

**References: 1) Introductory Circuits  
analysis by Boylistad  
2) Introductory AC Circuit  
theory by k mann and G I  
Russell**

# FIRST LECTURE

## 1. Sinusoidal Alternating Waveforms

### INTRODUCTION

The analysis thus far has been limited to dc networks, networks in which the currents or voltages are fixed in magnitude except for transient effects. We will now turn our attention to the analysis of networks in which the magnitude of the source varies in a set manner.

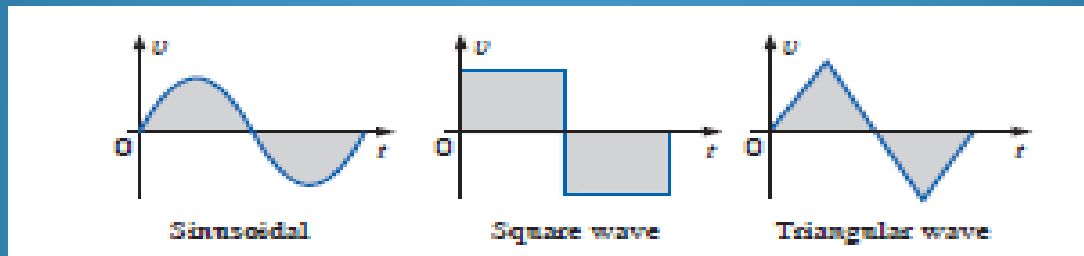

**SINUSOIDAL ac VOLTAGE**  
**CHARACTERISTICS AND DEFINITIONS**  
**Generation**

**Sinusoidal ac voltages are available from a variety of sources. The most common source is the typical home outlet, which provides an ac voltage that originates at a power plant; such a power plant is most commonly fueled by water power, oil, gas, or nuclear fusion. In each case an *ac generator* (also called an *alternator*), as shown in Fig. down, is the primary component in the energy-conversion process**

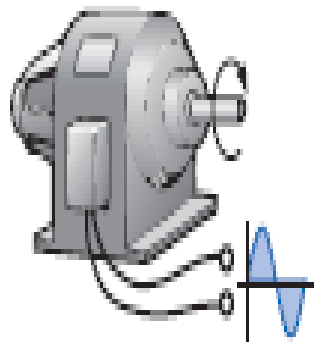
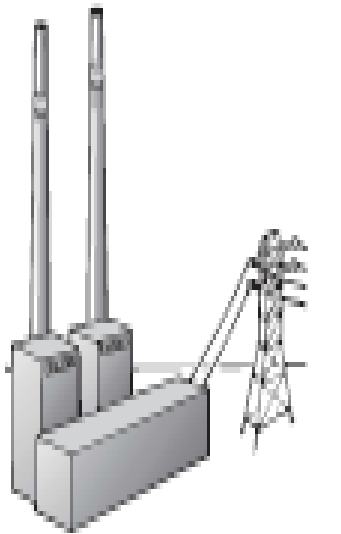

(a)

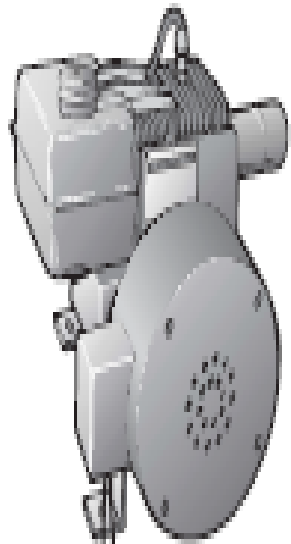

(b)

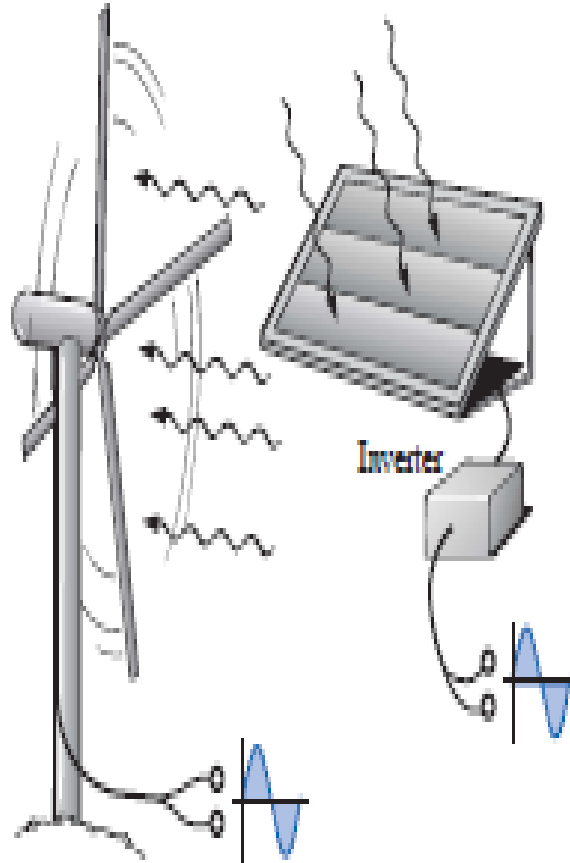

(d)

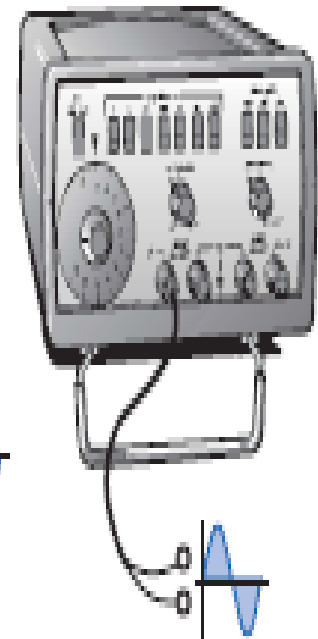

(e)

## Definitions

The sinusoidal waveform of Fig. down with its additional notation will now be used as a model in defining a few basic terms. These terms, however, can be applied to any alternating waveform.



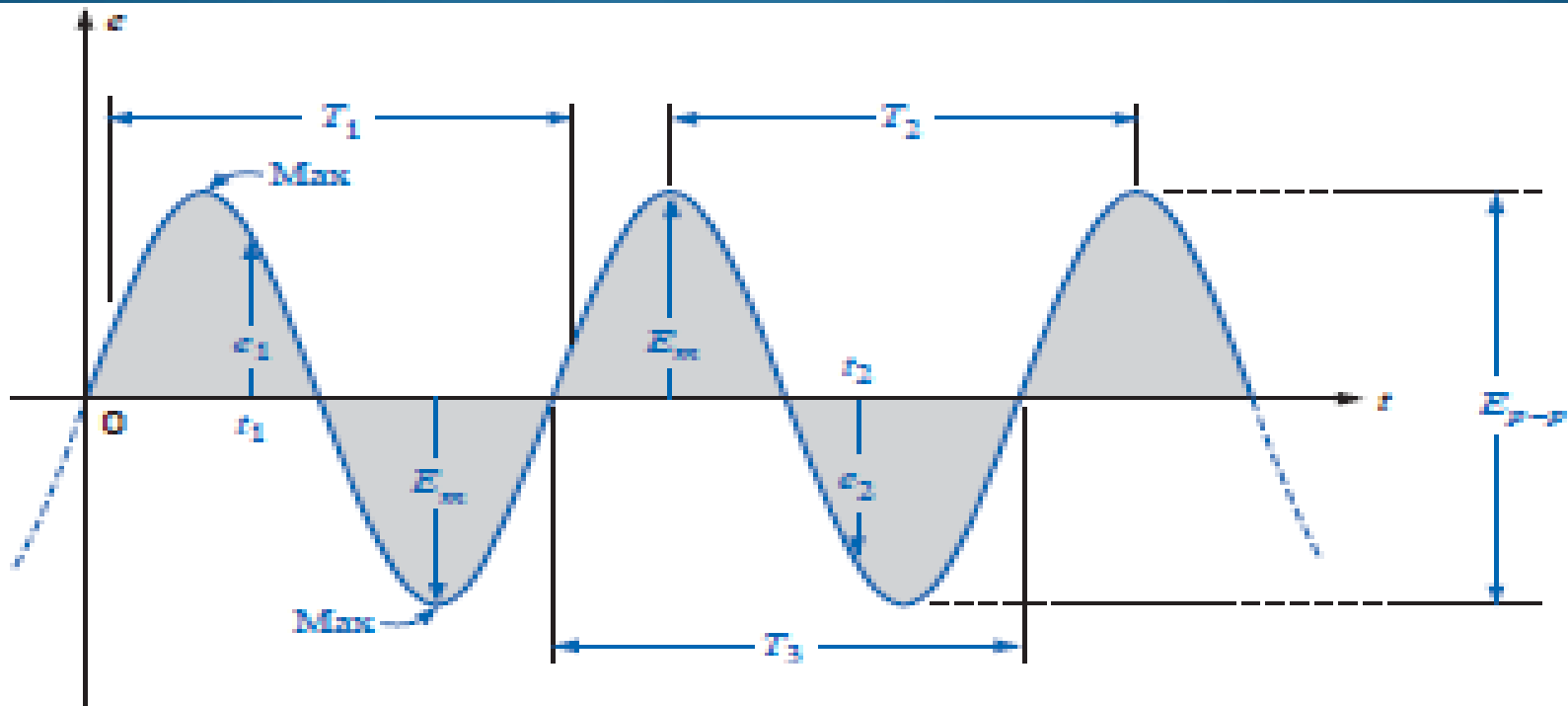

**Instantaneous value:** The magnitude of a waveform at any instant of time; denoted by lowercase letters ( $e_1$ ,  $e_2$ ). **Peak amplitude:** The maximum value of a waveform as measured from its *average*, or *mean*, value, denoted by uppercase letters (such as  $E_m$  for sources of voltage and  $V_m$  for the voltage drop across a load). For the waveform of Fig. 13.3, the average value is zero volts, and  $E_m$  is as defined by the figure. **Peak value:** The maximum instantaneous value of a function as measured from the zero-volt level. For the waveform of Fig. 13.3, the peak amplitude and peak value are the same, since the average value of the function is zero volts. **Peak-to-peak value:** Denoted by  $E_{p-p}$  or  $V_{p-p}$ , the full voltage between positive and negative peaks of the waveform, that is, the sum of the magnitude of the positive and negative peaks. **Periodic waveform:** A waveform that continually repeats itself after the same time interval. The waveform of Fig. 13.3 is a periodic waveform.

**Period ( $T$ ):** The time interval between successive repetitions of a periodic waveform (the period  $T_1$  \_  $T_2$  \_  $T_3$  in Fig. 13.3), as long as successive *similar points* of the periodic waveform are used in determining  $T$ .

**Cycle: The portion of a waveform contained in one period of time. The cycles within T1, T2, and T3 of Fig. 13.3 may appear different in Fig. down but they are all bounded by one period of time and therefore satisfy the definition of a cycle.**

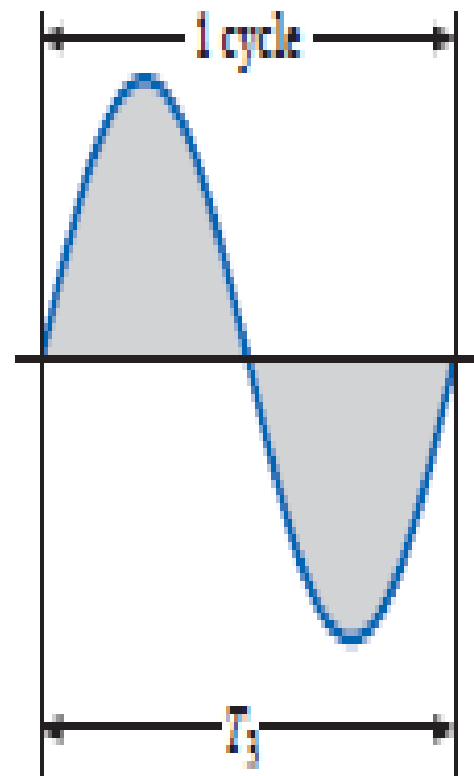
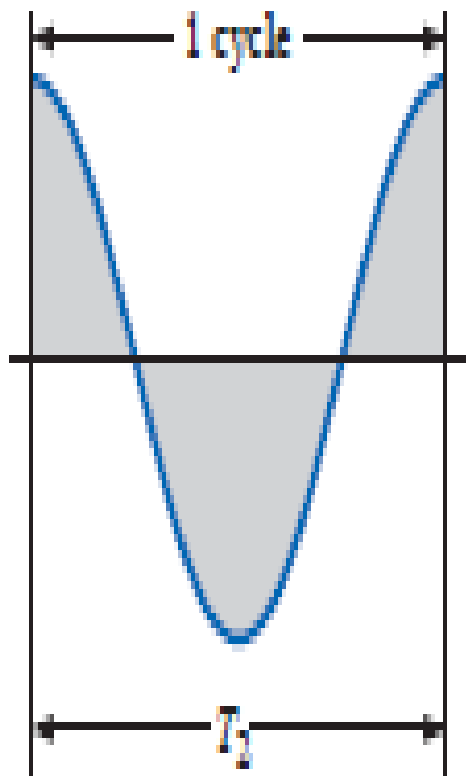
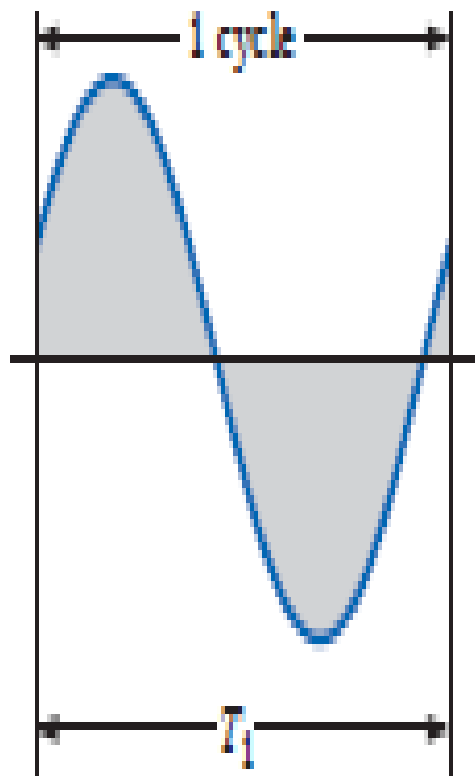

Frequency ( $f$ ): The number of cycles that occur in 1 s. The frequency of the waveform of Fig. 13.5(a) is 1 cycle per second, and for Fig. 13.5(b),  $2\frac{1}{2}$  cycles per second. If a waveform of similar shape had a period of 0.5 s [Fig. 13.5(c)], the frequency would be 2 cycles per second.

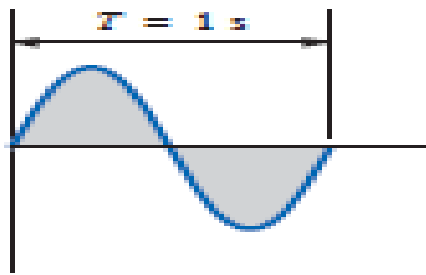

(a)

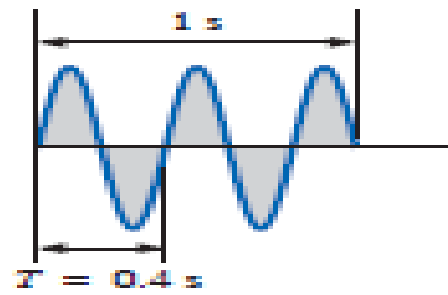

(b)

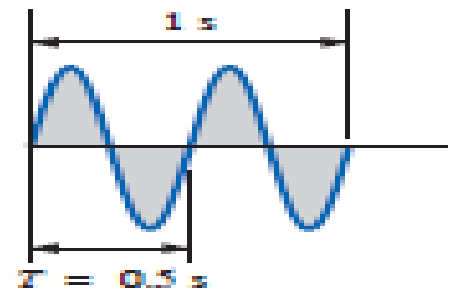

(c)